

STUDENT NAME _____

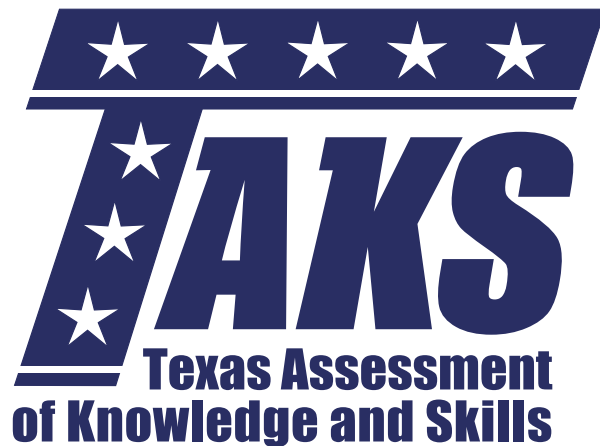

**GRADE 10
ENGLISH LANGUAGE ARTS
MATHEMATICS
SOCIAL STUDIES
SCIENCE**

Administered Spring 2004

MATHEMATICS

Mathematics Chart

LENGTH

Metric	Customary
1 kilometer = 1000 meters	1 mile = 1760 yards
1 meter = 100 centimeters	1 mile = 5280 feet
1 centimeter = 10 millimeters	1 yard = 3 feet
	1 foot = 12 inches

CAPACITY AND VOLUME

Metric	Customary
1 liter = 1000 milliliters	1 gallon = 4 quarts
	1 gallon = 128 ounces
	1 quart = 2 pints
	1 pint = 2 cups
	1 cup = 8 ounces

MASS AND WEIGHT

Metric	Customary
1 kilogram = 1000 grams	1 ton = 2000 pounds
1 gram = 1000 milligrams	1 pound = 16 ounces

TIME

1 year = 365 days
1 year = 12 months
1 year = 52 weeks
1 week = 7 days
1 day = 24 hours
1 hour = 60 minutes
1 minute = 60 seconds

Metric and customary rulers can be found on the separate Mathematics Chart.

Mathematics Chart

Perimeter	rectangle	$P = 2l + 2w$ or $P = 2(l + w)$
Circumference	circle	$C = 2\pi r$ or $C = \pi d$
Area	rectangle	$A = lw$ or $A = bh$
	triangle	$A = \frac{1}{2}bh$ or $A = \frac{bh}{2}$
	trapezoid	$A = \frac{1}{2}(b_1 + b_2)h$ or $A = \frac{(b_1 + b_2)h}{2}$
	circle	$A = \pi r^2$
Surface Area	cube	$S = 6s^2$
	cylinder (lateral)	$S = 2\pi rh$
	cylinder (total)	$S = 2\pi rh + 2\pi r^2$ or $S = 2\pi r(h + r)$
	cone (lateral)	$S = \pi rl$
	cone (total)	$S = \pi rl + \pi r^2$ or $S = \pi r(l + r)$
	sphere	$S = 4\pi r^2$
Volume	prism or cylinder	$V = Bh^*$
	pyramid or cone	$V = \frac{1}{3}Bh^*$
	sphere	$V = \frac{4}{3}\pi r^3$
<i>*B represents the area of the Base of a solid figure.</i>		
Pi	π	$\pi \approx 3.14$ or $\pi \approx \frac{22}{7}$
Pythagorean Theorem		$a^2 + b^2 = c^2$
Distance Formula		$d = \sqrt{(x_2 - x_1)^2 + (y_2 - y_1)^2}$
Slope of a Line		$m = \frac{y_2 - y_1}{x_2 - x_1}$
Midpoint Formula		$M = \left(\frac{x_1 + x_2}{2}, \frac{y_1 + y_2}{2} \right)$
Quadratic Formula		$x = \frac{-b \pm \sqrt{b^2 - 4ac}}{2a}$
Slope-Intercept Form of an Equation		$y = mx + b$
Point-Slope Form of an Equation		$y - y_1 = m(x - x_1)$
Standard Form of an Equation		$Ax + By = C$
Simple Interest Formula		$I = prt$

DIRECTIONS

Read each question. Then fill in the correct answer on your answer document. If a correct answer is not here, mark the letter for “Not here.”

SAMPLE A

Find the slope of the line $2y = 8x - 3$.

A $-\frac{3}{2}$

B 4

C 8

D Not here

SAMPLE B

Janice uses a rectangular box to store her art supplies. The dimensions of the rectangular box are 22.5 inches by 14 inches by 11.5 inches. What is the volume of this box in cubic inches?

Record your answer and fill in the bubbles on your answer document. Be sure to use the correct place value.



- 1 Simplify the algebraic expression

$$5(x + 3)(x + 2) - 3(x^2 + 2x + 1).$$

- A $2x^2 + 7$
- B $2x^2 + 27$
- C $2x^2 + 7x + 7$
- D $2x^2 + 19x + 27$

- 2 Mr. Harmon is planning to sell his house and wants to paint all the rooms. A can of paint costs \$12.95 plus 7.75% sales tax and covers about 476 square feet. What other information is needed to determine the number of cans of paint Mr. Harmon needs to purchase?

- F The number of rooms in the house
- G The area in square feet to be painted
- H The total cost of each can of paint
- J The name of the store where Mr. Harmon will buy the paint

- 3 Of the 800 students at a local high school, 200 students have no siblings, 318 students have one sibling, 160 students have two siblings, and the rest of the students have three or more siblings. Use the key below to find the circle graph that best represents this information.

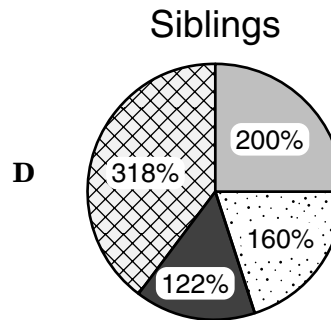
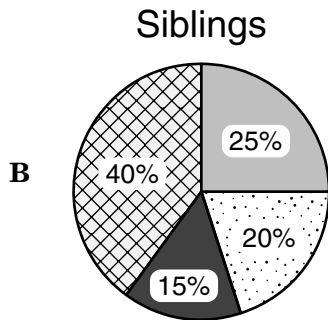
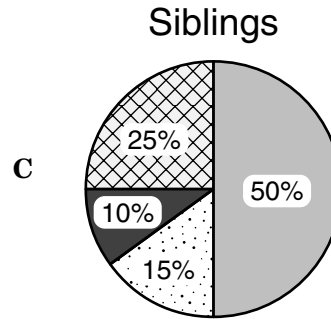
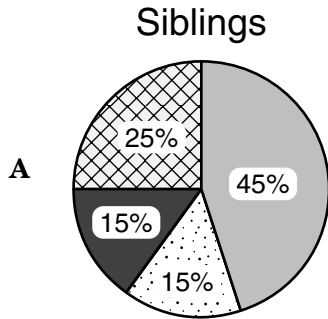
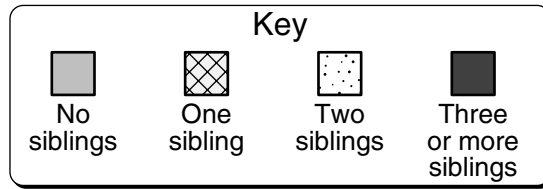

- 4 Which expression can be used to find the values of $s(n)$ in the table below?

n	1	2	3	4	5	6
$s(n)$	5	8	11	14	?	?

- F** $3n$
G $5n$
H $n + 4$
J $3n + 2$

- 5 A rectangle has an area of 144 square inches and a perimeter of 50 inches. What are the dimensions of the rectangle?

- A** 10 in. by 15 in.
B 9 in. by 16 in.
C 8 in. by 18 in.
D 4 in. by 36 in.

- 6 Which coordinate points represent the x - and y -intercepts of the graph shown below?

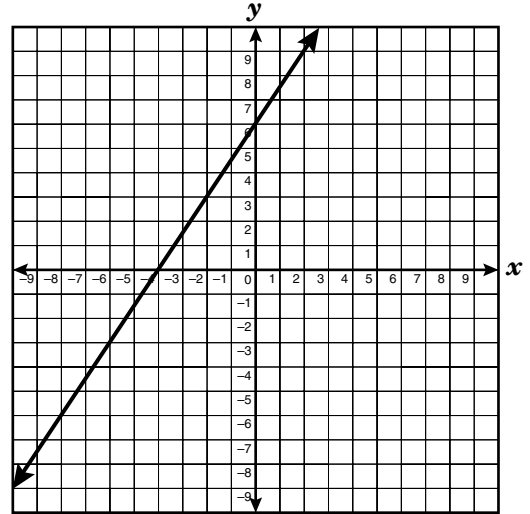

- F** $(0, -4)$ and $(6, 0)$
G $(-4, 0)$ and $(0, 6)$
H $(6, 0)$ and $(-4, 0)$
J $(0, 6)$ and $(0, -4)$

- 7 The school drama club plans to attend a Shakespeare festival in 6 weeks. The total cost per person is \$185.75. The club has \$296 in its account and will divide the money equally among the 8 members who attend the festival. Troy is planning to attend the festival and has already saved \$55. How much more money does Troy need in order to cover his cost to attend the festival?

- A** \$93.75
B \$110.25
C \$148.75
D Not here

- 8 What will happen to the slope of line p if the line is shifted so that the y -intercept increases and the x -intercept remains the same?

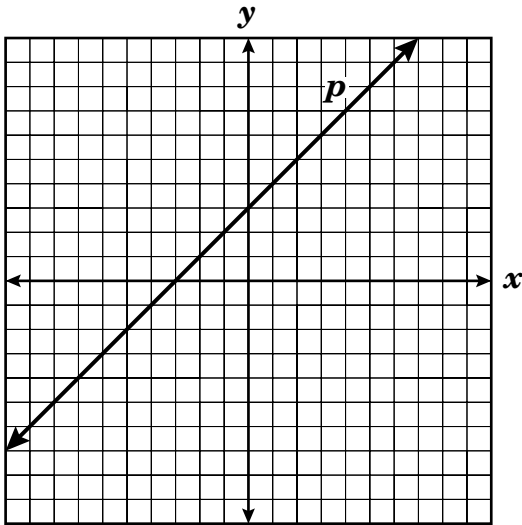

- F The slope will change from positive to negative.
- G The slope will change from negative to positive.
- H The slope will increase.
- J The slope will decrease.
- 9 The blueprint dimensions for a newly constructed house are proportional to the house's actual dimensions. On the blueprints the house's foundation measures 75 centimeters long by 40 centimeters wide. If the house's foundation measures 15 meters long, what is the foundation's actual width?

- A 8 m
- B 28.1 m
- C 50 m
- D 200 m

- 10 At what coordinates should vertex Z be placed to create a quadrilateral $WXYZ$ that is similar to quadrilateral $PQRS$?

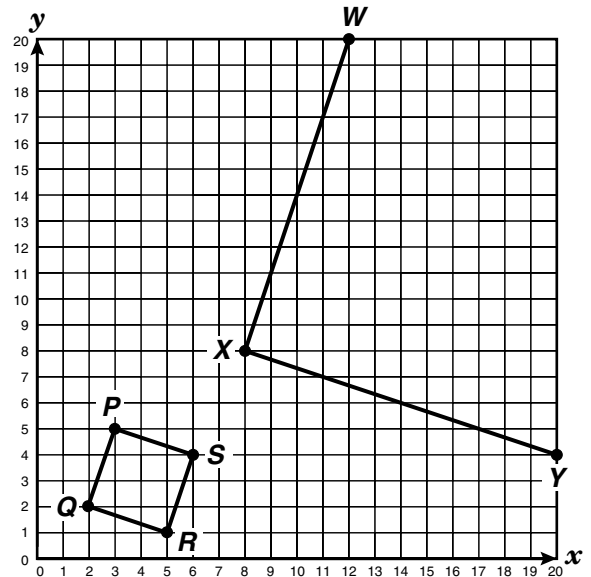

- F (24, 16)
- G (24, 24)
- H (20, 20)
- J (16, 24)

- 11 Linda owns a set of seven wrenches. The wrenches come in consecutive increments of $\frac{1}{8}$ inch. Linda has misplaced a wrench. The sizes she has are $\frac{1}{8}$ inch, $\frac{1}{4}$ inch, $\frac{1}{2}$ inch, $\frac{5}{8}$ inch, $\frac{3}{4}$ inch, and $\frac{7}{8}$ inch. Which size wrench is missing from Linda's set?

- A $\frac{3}{16}$ in.
 B $\frac{3}{8}$ in.
 C $\frac{11}{16}$ in.
 D Not here

- 12 The coaches of a group of debate teams answered a survey about hours of debate team practice and number of team wins. The graph shows the results of this survey.

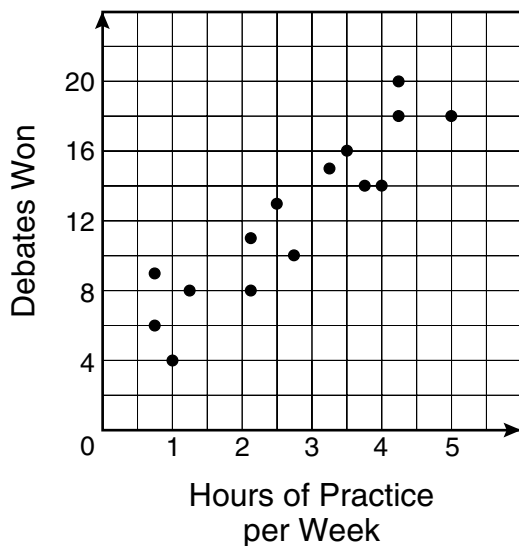

Based on these results, if a team practices 4 hours per week next season, which is the best estimate of the number of debates the team can expect to win?

- F 1
 G 12
 H 16
 J 20

- 13 The owners of Neatly Packaged Company make a cylindrical container that has the dimensions shown below.

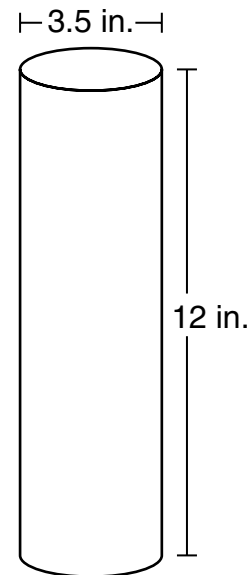

What is the approximate lateral surface area available for the package label?

- A 131.95 in.²
 B 151.19 in.²
 C 263.89 in.²
 D 115.45 in.²

- 14 Rita put some hummingbird feeders in her backyard. The table shows the number of hummingbirds that Rita saw compared to the number of feeders.

Bird-Watching

Number of Feeders	Number of Hummingbirds
1	3
2	5
3	7
4	9
5	11

Which equation best describes the relationship between h , the number of hummingbirds, and f , the number of feeders?

F $h = 2f + 1$

G $f = 2h + 1$

H $h = f + 2$

J $f = \frac{h + 1}{2} + 1$

- 15 Mrs. Cheung hired a landscaping service to plant a row of bushes around her triangular backyard.

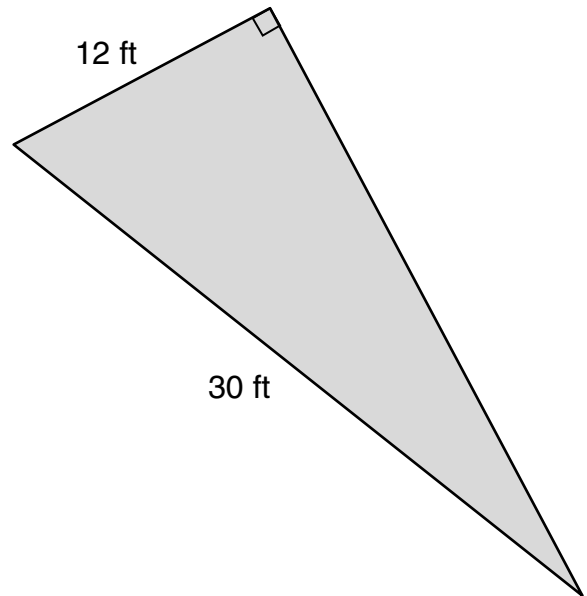

If the bushes must be planted 3 feet apart, approximately how many bushes are needed for Mrs. Cheung's backyard?

A 23

B 25

C 28

D 32

16 A copy machine can enlarge or reduce letters proportionately. Which would not be an enlargement or reduction of the letter below?

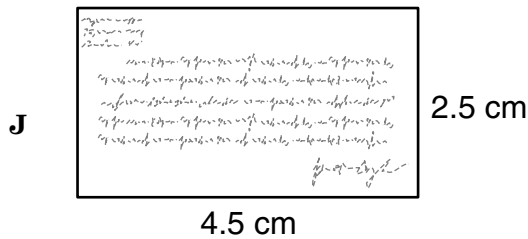
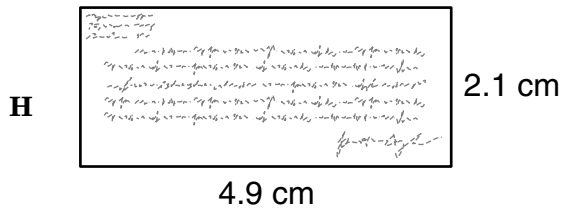
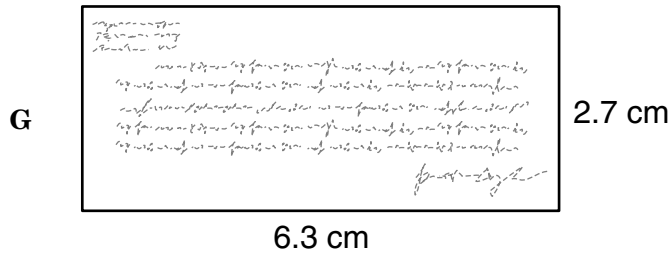
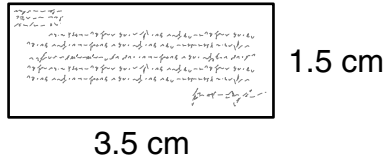

- 17 What is the effect on the graph of the equation $y = -4x^2$ when the equation is changed to $y = 4x^2$?
- A The graph of $y = 4x^2$ is translated 8 units down.
 - B The graph of $y = 4x^2$ is a reflection of $y = -4x^2$ across the x -axis.
 - C The graph of $y = 4x^2$ is translated 8 units up.
 - D The graph of $y = 4x^2$ is a reflection of $y = -4x^2$ across the y -axis.

- 18 A shaded parallelogram is graphed on the coordinate grid below.

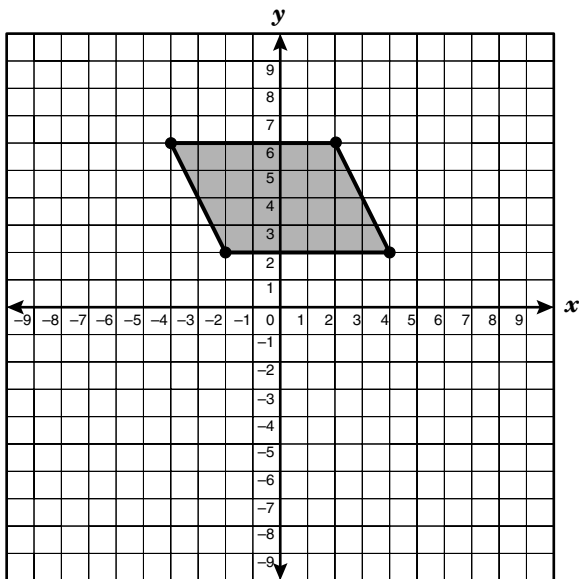

Which of the following functions describes a line that would include an edge of the shaded parallelogram?

- F $y = -2x + 5$
- G $y = -2x - 2$
- H $y = -2x + 9$
- J $y = -2x - 1$

- 19 A circle and its diameter are shown below.

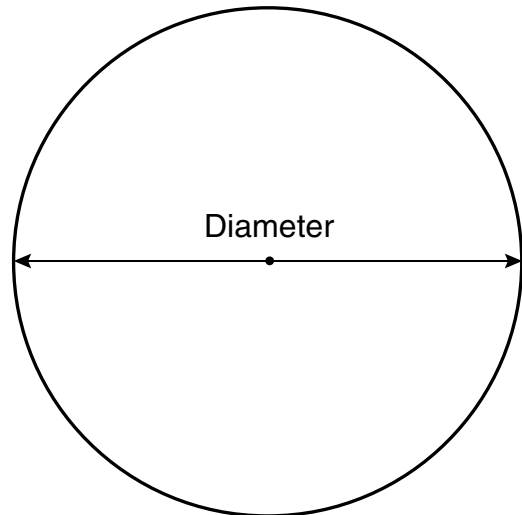

The value of π is the result of which of the following ratios comparing a circle's circumference to its diameter?

- A $\frac{C}{r}$
- B $\frac{d}{C}$
- C $\frac{r^2}{C}$
- D $\frac{C}{d}$

- 20 Which inequality best describes the graph shown below?

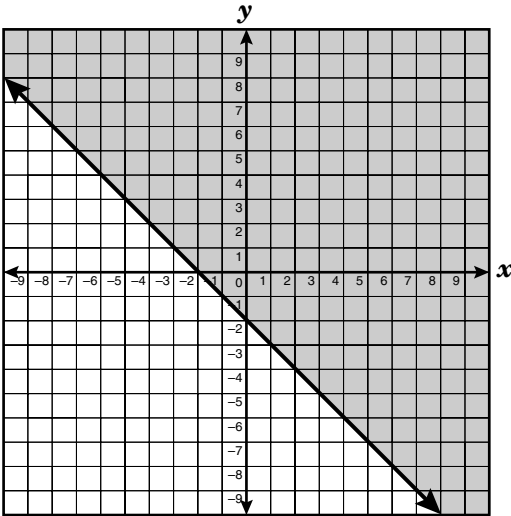

- F** $y \geq -2x$
G $y \geq -x - 2$
H $y \geq -2x - 2$
J $y \geq x - 2$

- 21 If the dimensions of a rectangle with a perimeter of 24 inches are tripled, what will be the perimeter in inches of the new rectangle?

Record your answer and fill in the bubbles on your answer document. Be sure to use the correct place value.

22 Which statement about the triangles below is true?

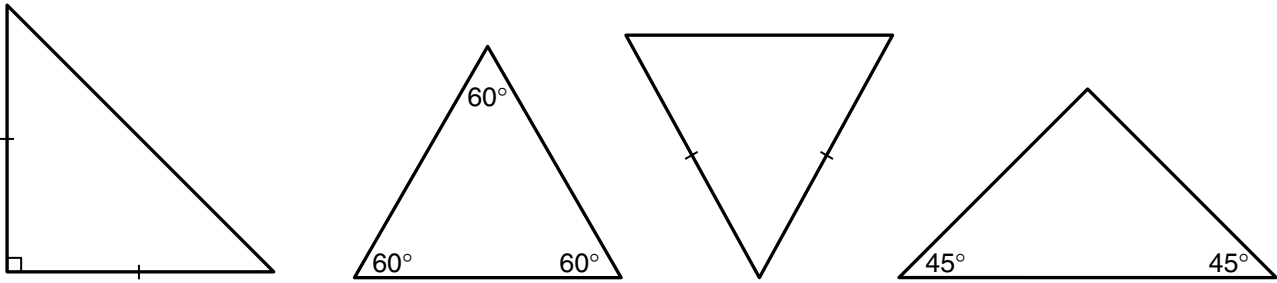

- F** All the triangles are scalene.
- G** All the triangles are equiangular.
- H** All the triangles are equilateral.
- J** All the triangles are isosceles.

23 The volume of a rectangular prism is given by the function $V = lwh$. Which statement is true?

- A** The volume of the prism depends on the product of only the length and the width.
- B** The volume of the prism depends on the product of only the length and the height.
- C** The volume of the prism depends on the product of the length, the width, and the height.
- D** The volume of the prism depends on the product of only the width and the height.

24 What is the x -coordinate of the solution to the system of linear equations below?

$$\begin{aligned}4x + 5y &= 8 \\ 2x - 3y &= -18\end{aligned}$$

- F** -4
- G** -3
- H** 3
- J** 4

25 Which expression is equivalent to $5(x^2 - 4x) - (x + 1)$?

- A $5x^2 - 21x + 1$
- B $5x^2 - 5x - 1$
- C $5x^2 - 21x - 1$
- D $5x^2 - 5x + 1$

26 What is the rate of change of the graph below?

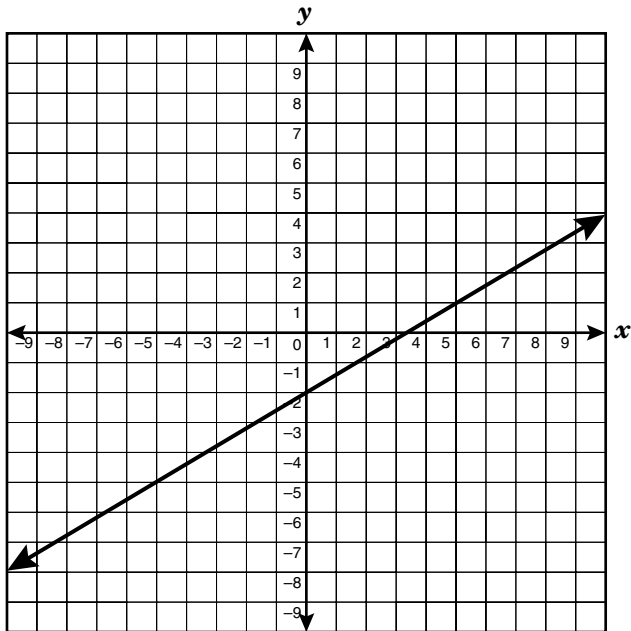

- F 3.5
- G 1.67
- H 0.6
- J -1.67

27 A triangular prism is shown below.

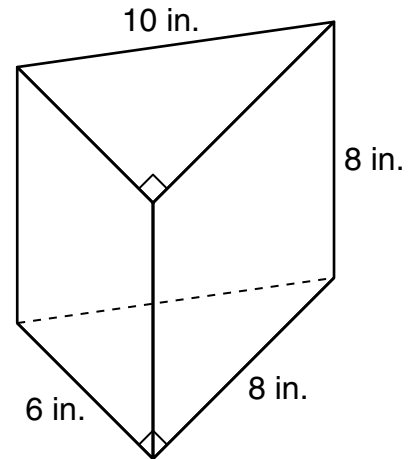

What is the volume of this triangular prism?

- A 192 in.^3
- B 240 in.^3
- C 384 in.^3
- D 480 in.^3

- 28 If quadrilateral $TUVW$ is reflected across the x -axis to become quadrilateral $T'U'V'W'$, what will be the coordinates of W' ?

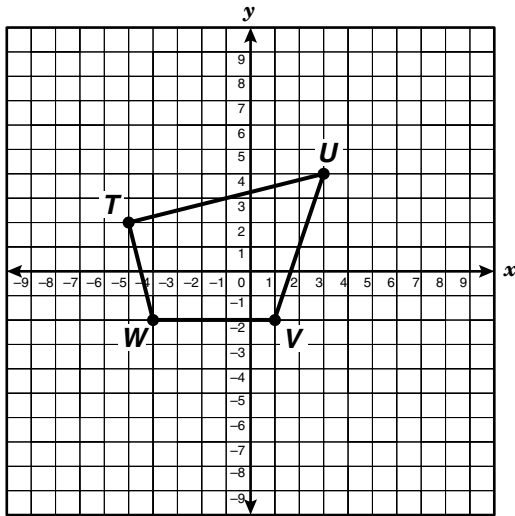

- F** $(-4, -2)$
G $(-4, 2)$
H $(2, -4)$
J $(4, -2)$

- 29 Of the 32 students in Mrs. Zane's class, 25% have brown hair. Of the remaining students, 12.5% have red hair. How many students in Mrs. Zane's class have red hair?

- A** 3
B 4
C 21
D Not here

- 30 Steven has a cylindrical fish tank with a diameter of 8 inches and a height of 14 inches. He placed some rocks that took up 50 cubic inches at the bottom of the tank. Then he filled the tank with springwater to 2 inches from the top. Which is the best strategy for determining the volume of water the fish has for swimming?

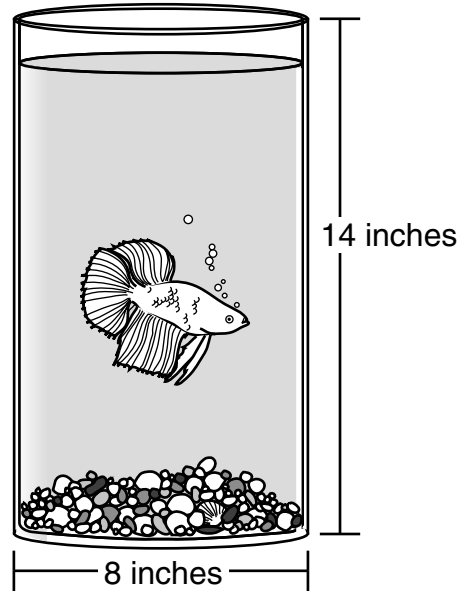

- F** $\pi(8)^2(14) - 50$
G $\pi(8)^2(14 - 2) - 50$
H $\pi(4)^2(14 - 2) - 50$
J $\pi(14 - 2)^2(4) - 50$

- 31 In the system of equations $4x + 2y = 10$ and $3x + 7y = -18$, which expression can be correctly substituted for y in the equation $3x + 7y = -18$?

- A** $10 - 2x$
B $10 + 2x$
C $5 - 2x$
D $5 + 2x$

- 32 Mrs. Franklin received a 7% raise at her job. If she was earning x dollars per year before, how much is she earning now?

F $x + 7$
G $x + 0.07$
H $x + 0.7x$
J $x + 0.07x$

- 33 Which expression is equivalent to $\frac{27x^{-2}y^6}{3x^5y^2z^0}$?

A $\frac{9x^7y^4}{z}$
B $\frac{y^4}{9x^3}$
C $\frac{9y^4}{x^7}$
D $\frac{9y^4}{x^7z}$

- 34 Nicholas earned the following grades on his science exams: 83, 88, 87, and 83. If Nicholas scores a 90 on his last exam, which measure of central tendency will give him the highest score?

F Mode
G Median
H Range
J Mean

- 35 Troy borrowed money from his father so that he could buy a used car. The table shows the remaining balance, b , of Troy's loan after each payment.

Troy's Loan Balance

Number of Payments, p	Loan Balance, b
1	\$3910
2	\$3685
3	\$3460
4	\$3235
5	\$3010
6	\$2785

Which function can be used to describe this relationship?

A $b = 3910 + 225p$
B $b = 4135 - 225p$
C $b = 2785 + 225p$
D $b = 3685 - 225p$

- 36 Look at the right triangle shown below. Which of the following could be the triangle's dimensions?

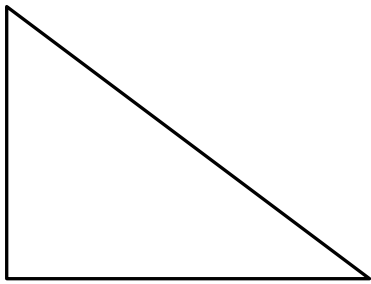

- F** 12, 16.8, 18.2
G 5.4, 10.6, 16
H 1.2, 1.6, 2
J 8, 10, 12.5

- 37 A portion of isosceles trapezoid $NPRT$ is shown on the grid below.

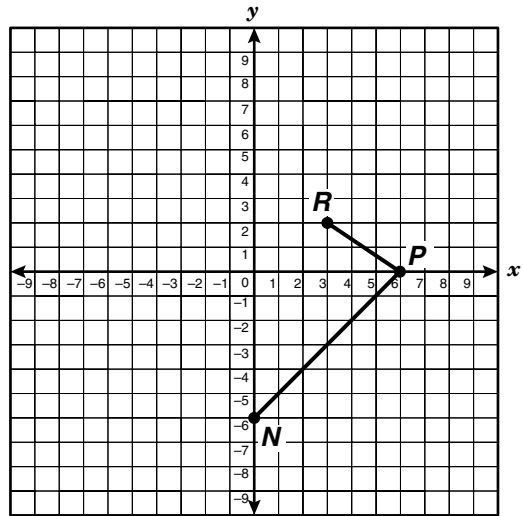

At what coordinates should vertex T be placed to make \overline{NP} parallel to \overline{RT} in order to complete isosceles trapezoid $NPRT$?

- A** $(-2, -2)$
B $(-3, -2)$
C $(-2, -3)$
D $(-4, -5)$

- 38 The net of a cylinder is shown below. Use the ruler on the Mathematics Chart to measure the dimensions of the cylinder to the nearest tenth of a centimeter.

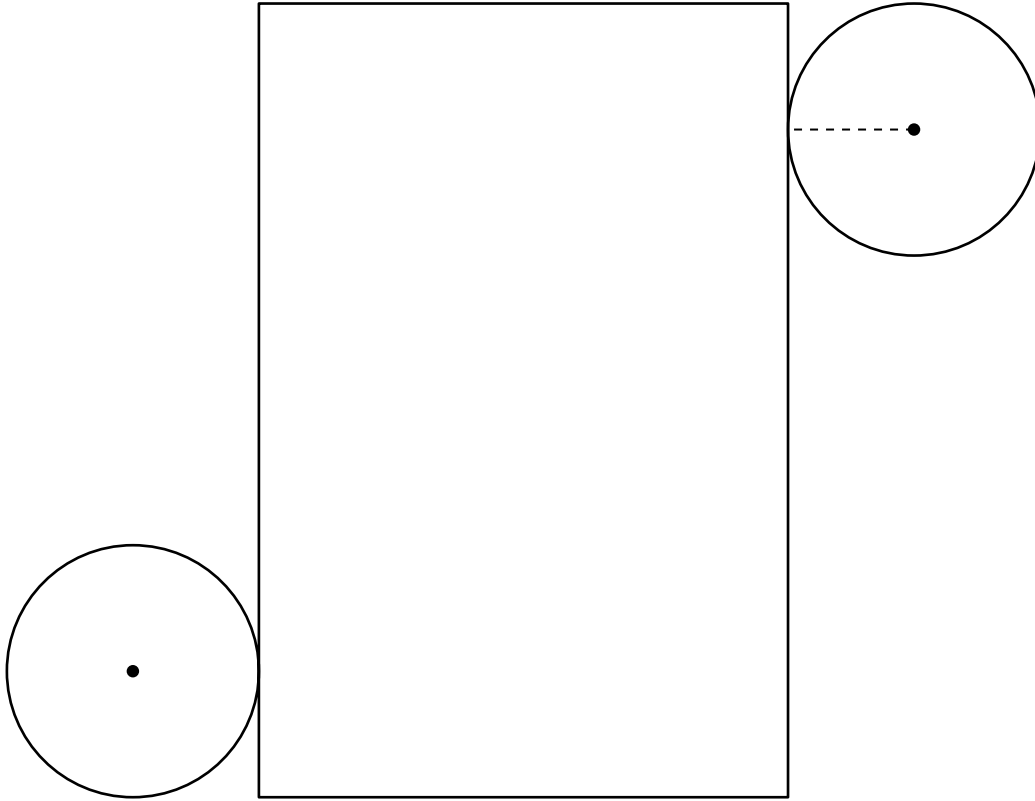

Which of the following best represents the total surface area of this cylinder?

- F** 142 cm^2
- G** 93 cm^2
- H** 23 cm^2
- J** 14 cm^2

39 The table below shows the population and the area in square miles of some U.S. states.

State	Population	Area (square miles)
Alaska	626,932	591,004
California	33,871,648	155,973
Florida	15,982,378	58,560
Montana	902,105	147,137
New Jersey	8,414,350	7,836
Texas	20,851,830	267,338

Which statement best describes the relationship between the population and the area of a state?

- A** The larger a state's area, the larger its population is.
- B** No relationship can be determined from the data in the table.
- C** New Jersey has the smallest population of the states in the table because it has the smallest area.
- D** Texas is the largest U.S. state.

- 40 What are the roots of the function graphed below?

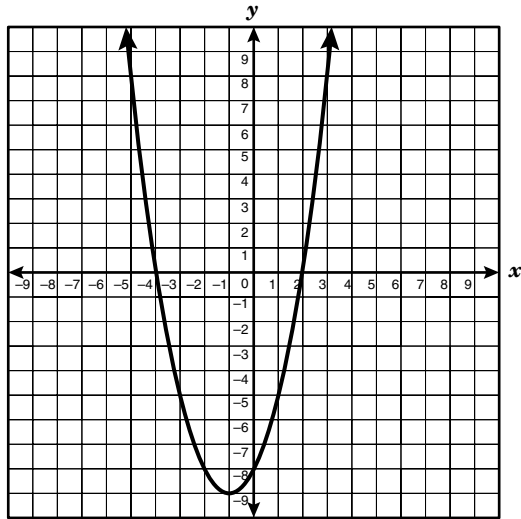

- F** $(-1, -9)$ and $(0, -8)$
G $(0, -4)$ and $(2, 0)$
H $(-4, 0)$ and $(2, 0)$
J $(0, 2)$ and $(0, -4)$

- 41 Near the downtown area of a city, there is a vacant triangular plot of land with sides that measure 22 feet, 27 feet, and 17 feet. If the city council decides to plant an oak tree in the corner with the smallest angle, where should the tree be planted?

- A** In the corner opposite the side that is 17 feet
B In the corner opposite the side that is 22 feet
C In the corner opposite the side that is 27 feet
D In the center of the triangular plot

- 42 To estimate the height of her school's gym, Nicole sights the top of the gym wall in a mirror that she has placed on the ground. The mirror is 3.6 meters from the base of the gym wall.

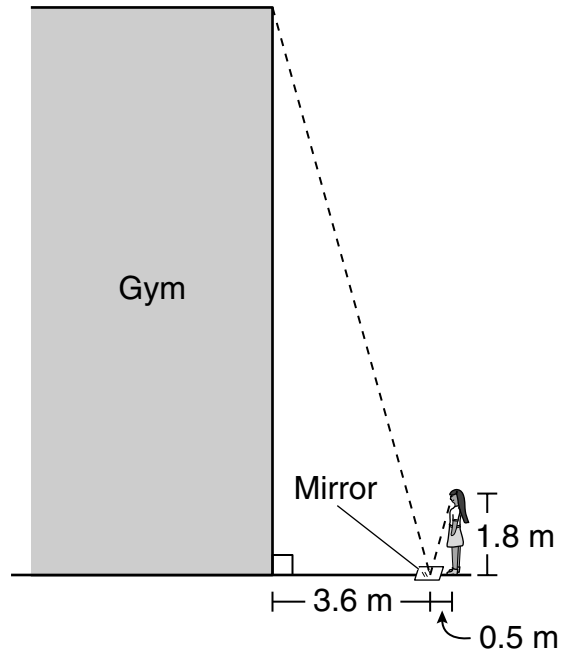

Nicole is standing 0.5 meter from the mirror, and her height is about 1.8 meters. What is the height of the gym wall?

- F** 1 m
G 5.9 m
H 7.2 m
J 12.96 m

- 43 The table below shows the results of a number cube being rolled.

Outcome	Frequency
1	6
2	2
3	2
4	3
5	2
6	0

Based on these results, what is the experimental probability of rolling a 1?

- A 2.5%
- B $\frac{1}{6}$
- C $\frac{2}{5}$
- D 0.6

- 44 Which equation describes the line that passes through the point (4, 7) and is parallel to the line represented by the equation $-3x + y = 4$?

F $y = -3x + 19$

G $y = 3x - 5$

H $y = \frac{1}{3}x + 5\frac{2}{3}$

J $y = -\frac{1}{3}x + 8\frac{1}{3}$

- 45 How does the graph of $y = x^2$ differ from the graph of $y = x^2 - 4$?
- A The graph of $y = x^2 - 4$ is wider than the graph of $y = x^2$.
- B The graph of $y = x^2 - 4$ is shifted to the left of the graph of $y = x^2$.
- C The graph of $y = x^2 - 4$ is shifted down from the graph of $y = x^2$.
- D The graph of $y = x^2 - 4$ is narrower than the graph of $y = x^2$.

46 In 1998 the enrollment at a community college was approximately 2500 students. In 2002 the enrollment had increased to 3250 students. If the enrollment continues to increase at this rate, what is a reasonable projection of enrollment for 2010?

- F 4750
- G 5750
- H 6250
- J 9000

47 A pattern exists as a result of raising i , an imaginary number, to n , an integer greater than or equal to 1.

Powers of i

i^n ($n \geq 1$)	Solution
i^1	$\sqrt{-1}$
i^2	-1
i^3	$-i$
i^4	1
i^5	$\sqrt{-1}$
i^6	-1

Based on the table, which of the following best represents i raised to the 16th power?

- A $\sqrt{-1}$
- B -1
- C $-i$
- D 1

48 Which point on the grid satisfies the conditions $x \geq 5$ and $y < -1$?

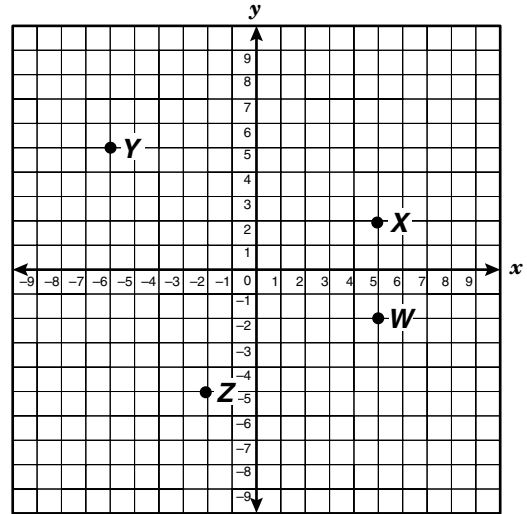

- F W
- G X
- H Y
- J Z

- 49 A candy company sells chocolate-covered cherries in a box. The empty box weighs 4.2 ounces. Each piece of candy weighs at least 1.8 ounces. Which inequality best describes the total weight in ounces, w , of a box of chocolate-covered cherries in terms of c , the number of candies in the box?

- A $w \geq 1.8c + 4.2$
B $w \geq 1.8c - 4.2$
C $w \geq 4.2c + 1.8$
D $w \geq 4.2c - 1.8$

- 50 Mr. Harrison wants to calculate the cost of buying a carpet to cover his rectangular living room floor. He knows the cost per square foot of carpet, and he knows the length, width, and height of the living room. Which geometric formula should Mr. Harrison use to determine the cost of the carpet he needs?

- F $c^2 = a^2 + b^2$
G $V = Bh$
H $A = lw$
J $P = 2l + 2w$

- 51 The graph below best represents which of the following relationships between temperature and time?

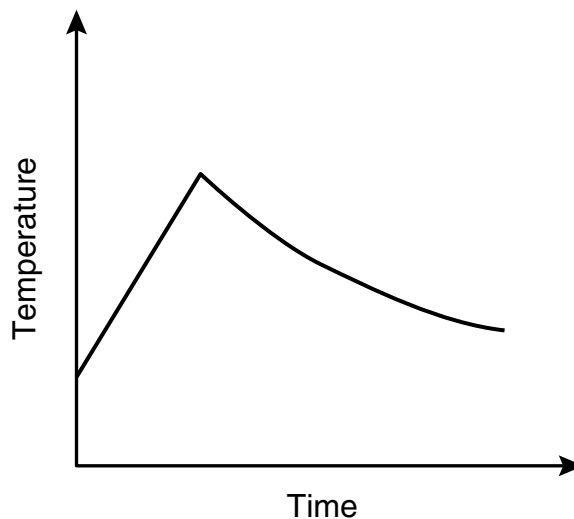

- A Oven temperature while a cake is baking
B Temperature of water that is heated on a stove, removed, and then allowed to cool
C Temperature of a container of hot tea after placing several cubes of ice in it
D Room temperature of a gym after the air conditioner is turned on

52 Which graph best represents the function $y = -1.75x + 5$?

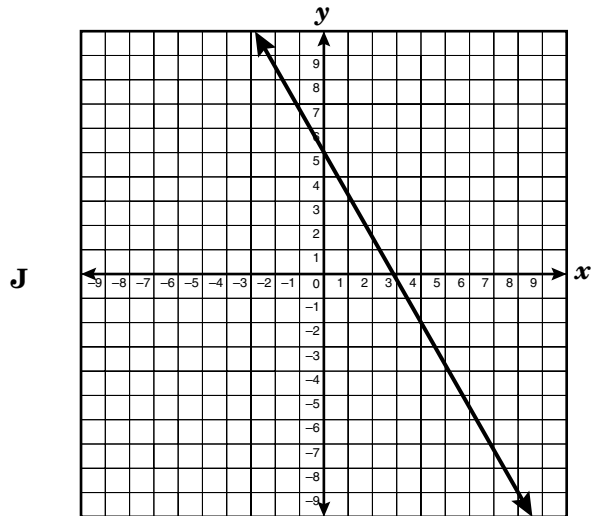
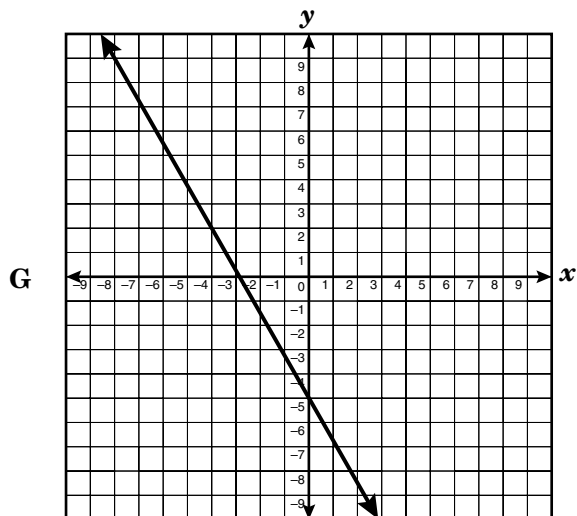
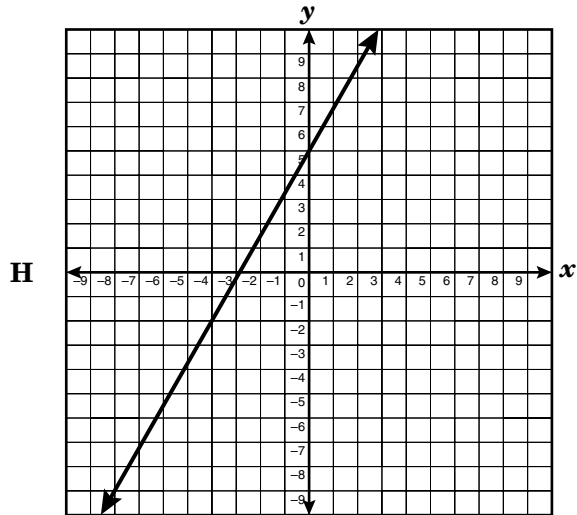
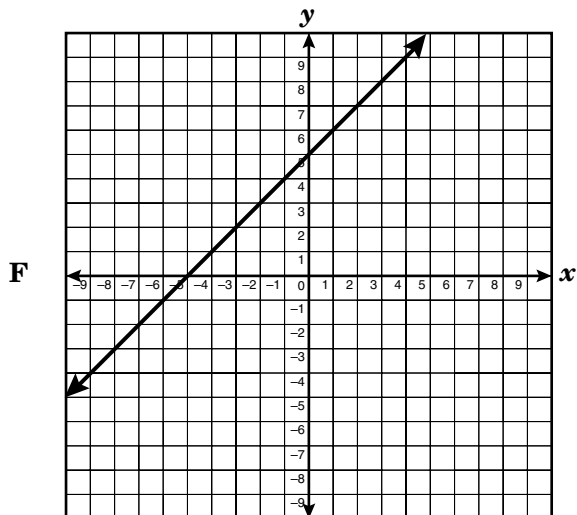

53 Shannon has spent \$850 on gasoline and repairs for her car in the last 6 months. Of this total, she spent \$300 on repairs. The gasoline she purchased cost \$1.29 per gallon. Which of the following can be used to determine how many gallons of gas, g , Shannon has bought within the last 6 months?

A $1.29g - 300 = 850$

B $1.29g + 300 = 850$

C $1.29 - 300g = 850$

D $1.29 + 300g = 850$

54 Chase and Sara went to the candy store. Chase bought 5 pieces of fudge and 3 pieces of bubble gum for a total of \$5.70. Sara bought 2 pieces of fudge and 10 pieces of bubble gum for a total of \$3.60. Which system of equations could be used to determine the cost of 1 piece of fudge, f , and 1 piece of bubble gum, g ?

F $5f + 3g = 3.60$
 $2f + 10g = 5.70$

G $5f + 2g = 5.70$
 $3f + 10g = 3.60$

H $f + g = 22$
 $7f + 13g = 9.30$

J $5f + 3g = 5.70$
 $2f + 10g = 3.60$

- 55 The graph below shows h , the height in meters of a model rocket, versus t , the time in seconds after the rocket is launched. From the graph, what conclusion can be made about the flight of the rocket?

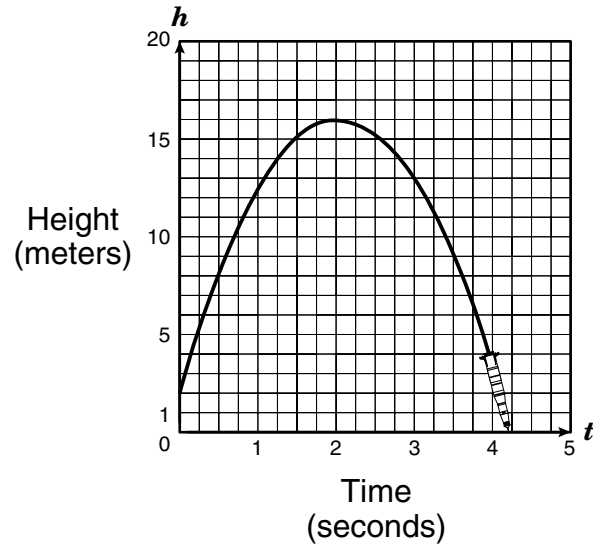

- A The rocket reached its maximum height after 2.5 seconds.
- B At 0 seconds the rocket was 2 meters off the ground.
- C The height of the rocket was 0 meters when it was launched.
- D The rocket was in flight for 5 seconds.

- 56 The drawing shows the top view of a structure built with cubes as well as the number of cubes in each column of the structure.

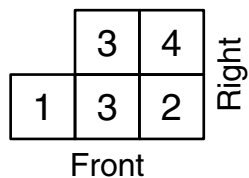

Which 3-dimensional view represents the same structure?

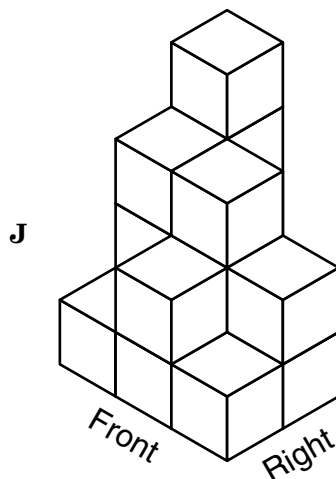
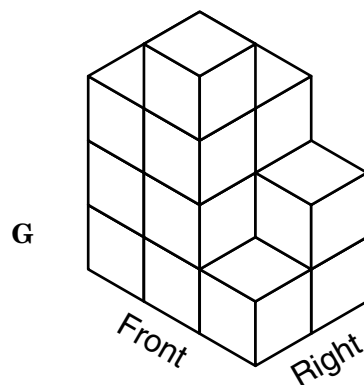
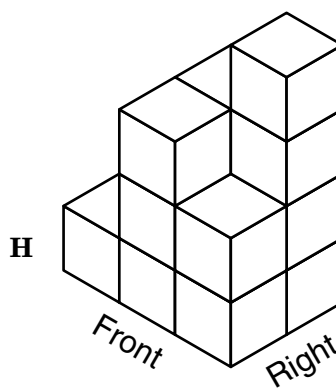
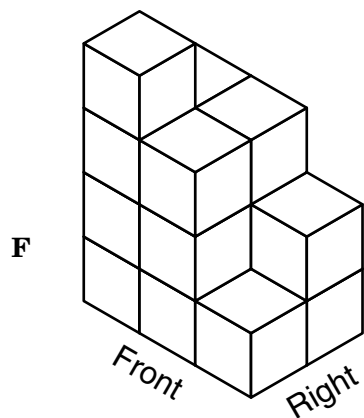

BE SURE YOU HAVE RECORDED ALL OF YOUR ANSWERS
ON THE ANSWER DOCUMENT.



