

STUDENT NAME \_\_\_\_\_

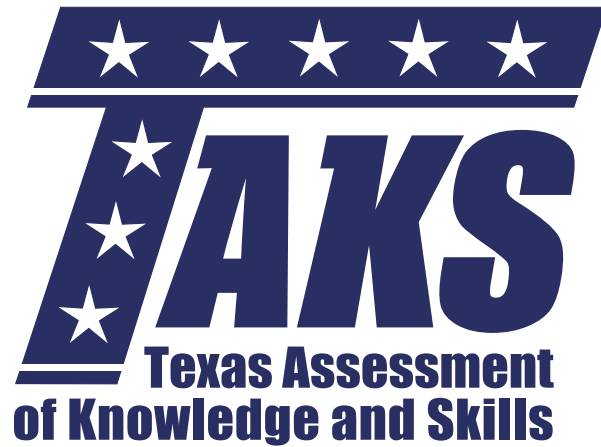

**GRADE 6  
MATHEMATICS  
READING**

**Administered Spring 2003**

# MATHEMATICS

# Mathematics Chart

## LENGTH

### Metric

1 kilometer = 1000 meters

1 meter = 100 centimeters

1 centimeter = 10 millimeters

### Customary

1 mile = 1760 yards

1 mile = 5280 feet

1 yard = 3 feet

1 foot = 12 inches

## CAPACITY AND VOLUME

### Metric

1 liter = 1000 milliliters

### Customary

1 gallon = 4 quarts

1 gallon = 128 ounces

1 quart = 2 pints

1 pint = 2 cups

1 cup = 8 ounces

## MASS AND WEIGHT

### Metric

1 kilogram = 1000 grams

1 gram = 1000 milligrams

### Customary

1 ton = 2000 pounds

1 pound = 16 ounces

## TIME

1 year = 365 days

1 year = 12 months

1 year = 52 weeks

1 week = 7 days

1 day = 24 hours

1 hour = 60 minutes

1 minute = 60 seconds

Metric and customary rulers can be found on the separate Mathematics Chart.

# Mathematics Chart

<b>Perimeter</b>	square	$P = 4s$
	rectangle	$P = 2l + 2w$ or $P = 2(l + w)$
<b>Circumference</b>	circle	$C = 2\pi r$ or $C = \pi d$
<b>Area</b>	square	$A = s^2$
	rectangle	$A = lw$ or $A = bh$
	triangle	$A = \frac{1}{2}bh$ or $A = \frac{bh}{2}$
	trapezoid	$A = \frac{1}{2}(b_1 + b_2)h$ or $A = \frac{(b_1 + b_2)h}{2}$
	circle	$A = \pi r^2$
<b>Volume</b>	cube	$V = s^3$
	rectangular prism	$V = lwh$
<b>Pi</b>	$\pi$	$\pi \approx 3.14$ or $\pi \approx \frac{22}{7}$

## DIRECTIONS

Read each question. Then fill in the correct answer on your answer document. If a correct answer is not here, mark the letter for "Not Here."

### SAMPLE A

Find the greatest common factor of 12 and 18.

- A 3
- B 6
- C 9
- D Not Here

### SAMPLE B

Find the perimeter of this square rug in meters.

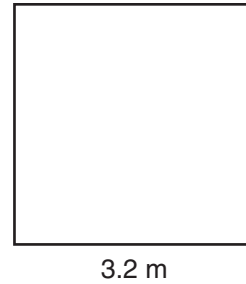

Record your answer and fill in the bubbles on your answer document. Be sure to use the correct place value.



- 1 Cynthia surveyed the students at her school about their favorite month during the school year. The table below shows the results of the survey.

Favorite Months

Month	Number of Students
October	240
December	360
February	300
May	420

Which graph correctly displays the data in the table?

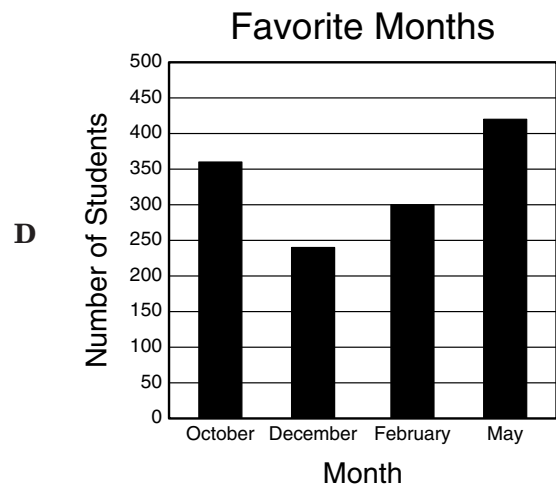
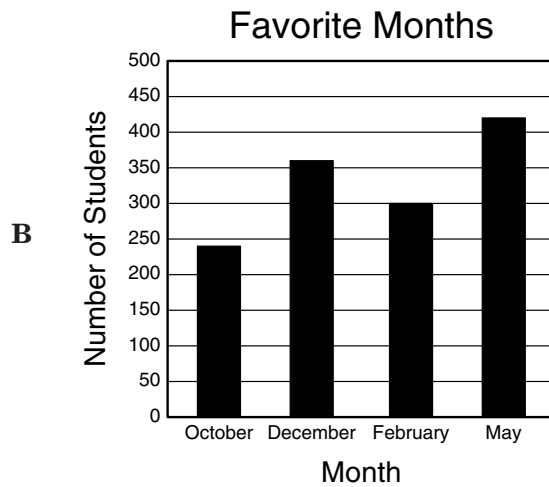
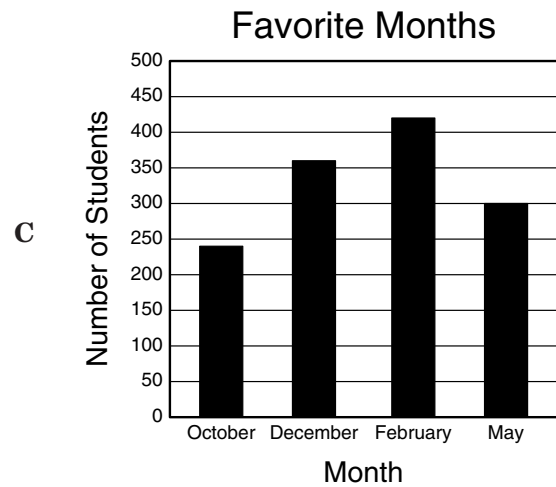
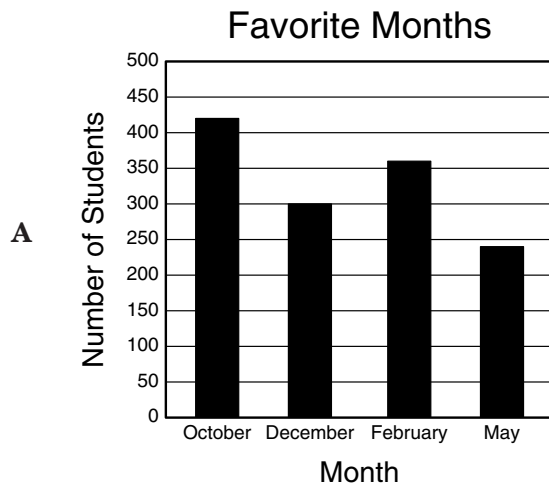

- 2 When Marco's dog got loose, it ran  $\frac{1}{3}$  mile on Pine Street,  $1\frac{1}{2}$  miles on Oak Street, and  $2\frac{5}{6}$  miles on Hickory Street. Which procedure can Marco use to find the total distance in miles that his dog ran?
- F** Multiply the sum of the whole numbers by the sum of the fractions, using a common denominator when necessary
- G** Find the difference between the sum of the whole numbers and the sum of the fractions, using a common denominator when necessary
- H** Add the sum of the whole numbers and the sum of the fractions, using a common denominator when necessary
- J** Divide the sum of the whole numbers by the sum of the fractions, using a common denominator when necessary

- 3 Cindy and 2 friends ordered a large pizza for \$9.00, 3 large drinks for \$0.99 each, and a salad for \$1.50. If they split these costs evenly, which equation can be used to find  $c$ , the amount in dollars and cents each person should pay, not including tax?
- A**  $c = 9.00 + 0.99 + 1.50 \div 3$
- B**  $c = 9.00 + 3 \times 0.99 + (1.50 \div 3)$
- C**  $c = (9.00 + 0.99 + 1.50) \div 2$
- D**  $c = (9.00 + 3 \times 0.99 + 1.50) \div 3$

- 4 What kind of angle is  $\angle N$ ?

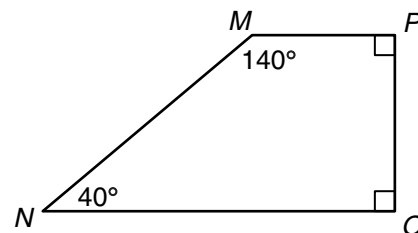

- F** Acute
- G** Right
- H** Obtuse
- J** Straight

- 5 In which of the pictures below does  $\angle P$  appear to be an obtuse angle?

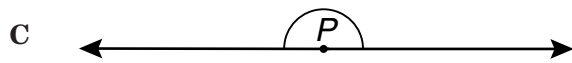
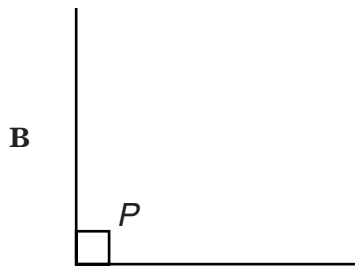
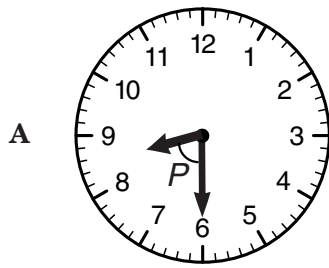

- 6 The line plot shows the homework grades of the students in Mrs. Smith's class.

Homework Grades

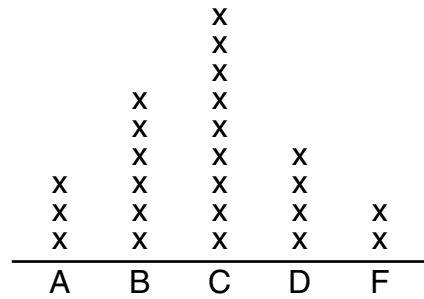

Which statement is supported by the information in the line plot?

- F The same number of students received a B as received a D.
- G Eighteen students received a C or higher.
- H The same number of students received a D or an F as received an A or a B.
- J Sixteen students received a C or lower.

- 7 Sam recorded the lengths of his model cars in inches. Which list shows the lengths in order from greatest to least?
- A 6.8 in., 6.78 in., 6.45 in., 6.5 in., 6.34 in.
  - B 6.34 in., 6.45 in., 6.5 in., 6.78 in., 6.8 in.
  - C 6.8 in., 6.78 in., 6.45 in., 6.34 in., 6.5 in.
  - D 6.8 in., 6.78 in., 6.5 in., 6.45 in., 6.34 in.

- 8 Laurence was asked to find 2 integers that have a difference of 1 and a sum of 59. He said the integers were 29 and 28. Why was Laurence's answer incorrect?
- F The difference between 29 and 28 is not 1.
  - G The difference between 29 and 28 is 1.
  - H The sum of 29 and 28 is 59.
  - J The sum of 29 and 28 is not 59.

- 9 Anna's brother is 117 centimeters tall. How is 117 centimeters expressed in meters?
- A 0.117 m
  - B 1.17 m
  - C 11.7 m
  - D 117 m

- 10 The ratio of red rosebushes to yellow rosebushes in the school garden is about 3 to 4. If there were 36 yellow rosebushes, about how many red rosebushes would there be?

- F 36
- G 32
- H 27
- J 12

- 11 Mr. Ortega gave his social studies students a map of Texas. According to the map scale, 1 inch on the map represents 100 actual miles. Which strategy can Mr. Ortega's students use to find the actual distance in miles between points on the map?
- A Measure the number of inches between points and then divide by 100
  - B Measure the number of inches between points and then multiply by 100
  - C Measure the number of inches between points and then subtract 100
  - D Measure the number of inches between points and then add 100

- 12 Mara plans to buy fabric for two sewing projects. One project requires  $\frac{1}{8}$  yard of fabric, and the other requires  $\frac{3}{4}$  yard of fabric. Each strip below represents 1 yard of fabric. Which strip is shaded to show the total amount of fabric that Mara needs for her projects?



- 13 Stan must buy paper plates and plastic forks for a picnic. Plates are sold in packages of 8 and forks in packages of 12. What is the least number of packages of plates and packages of forks that Stan can buy to have an equal number of plates and forks?

- A** 2 packages of plates and 3 packages of forks
- B** 3 packages of plates and 2 packages of forks
- C** 4 packages of plates and 6 packages of forks
- D** 6 packages of plates and 4 packages of forks

- 14 Find the prime factorization of 60.

- F**  $3^2 \cdot 10$
- G**  $2 \cdot 3 \cdot 10$
- H**  $2 \cdot 2 \cdot 15$
- J**  $2^2 \cdot 3 \cdot 5$

- 15 Corinne's group was responsible for painting windows on the set of a school play. The group painted 18 windows in 90 minutes. If they continued painting at this rate, how many windows would they paint in 3 hours?

- A** 24
- B** 36
- C** 54
- D** 72

- 16 Amy, Jasmine, Katrina, and Myra each walked from their houses to the mall. Amy walked  $\frac{1}{2}$  mile, Jasmine walked  $\frac{1}{4}$  mile, Katrina walked  $\frac{3}{4}$  mile, and Myra walked  $\frac{5}{8}$  mile. Which list shows these distances in order from greatest to least?

F  $\frac{1}{2}$  mi,  $\frac{1}{4}$  mi,  $\frac{3}{4}$  mi,  $\frac{5}{8}$  mi

G  $\frac{3}{4}$  mi,  $\frac{5}{8}$  mi,  $\frac{1}{2}$  mi,  $\frac{1}{4}$  mi

H  $\frac{1}{4}$  mi,  $\frac{1}{2}$  mi,  $\frac{5}{8}$  mi,  $\frac{3}{4}$  mi

J  $\frac{5}{8}$  mi,  $\frac{3}{4}$  mi,  $\frac{1}{4}$  mi,  $\frac{1}{2}$  mi

- 17 The side lengths and perimeters of some regular polygons are shown in the table below.

Regular Polygons

Side Length (inches)	Perimeter (inches)
4	20
6	30
8	40
10	50

Which geometric figure is represented by the information in the table?

- A Pentagon
- B Square
- C Hexagon
- D Triangle

- 18 By 2:30 P.M. on Monday, 25% of the classes at Valley Middle School had finished taking yearbook pictures. What fractional part of the classes had NOT yet taken yearbook pictures?

F  $\frac{1}{25}$

G  $\frac{1}{4}$

H  $\frac{2}{5}$

J  $\frac{3}{4}$

- 19 A parallelogram is shown below.

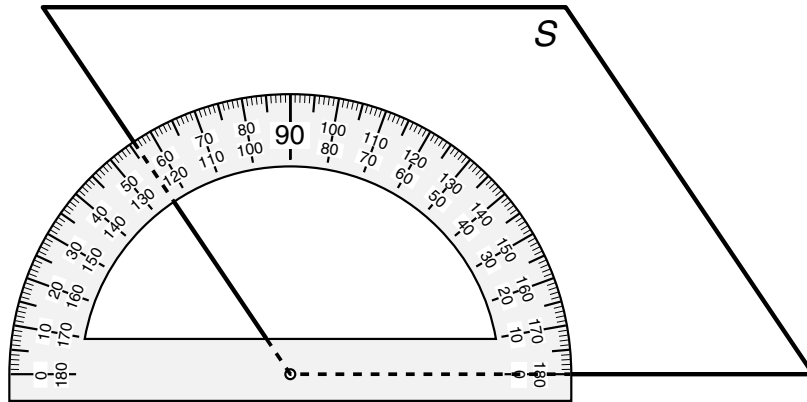

Find the measure of  $\angle S$  to the nearest degree.

- A 136°  
B 124°  
C 64°  
D 56°
- 
- 20 Stephanie bought a basketball on sale for \$15, which was  $\frac{1}{5}$  off the original price. What decimal represents the discount she received?

- F 0.05  
G 0.15  
H 0.20  
J 0.50

- 21 Lauren cut a triangle out of construction paper for a geometry project.

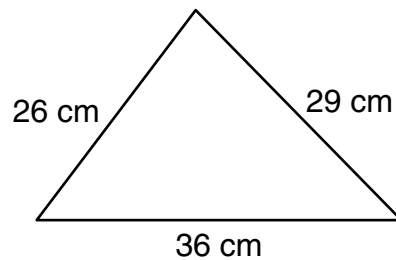

Find the perimeter of the triangle in centimeters.

Record your answer and fill in the bubbles on your answer document. Be sure to use the correct place value.

- 22 Charlie had 1 red marble, 1 blue marble, 1 yellow marble, and 1 green marble in a bag. He picked 2 marbles at random from the bag. Which diagram shows all the possible color combinations of the 2 marbles that Charlie picked?

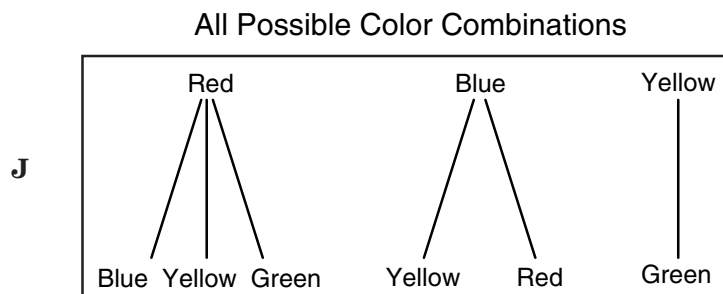
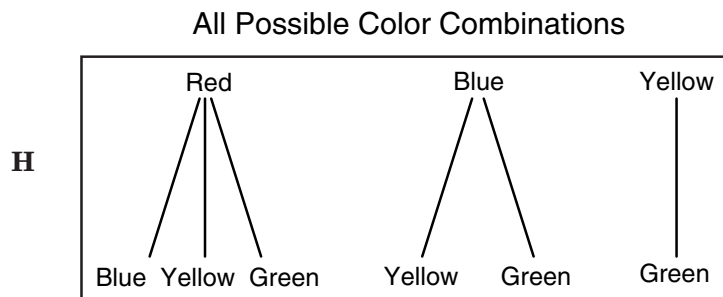
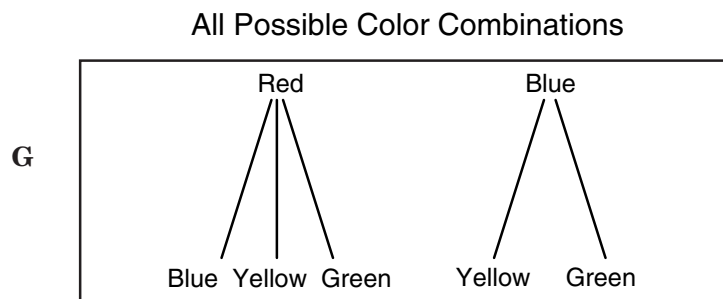
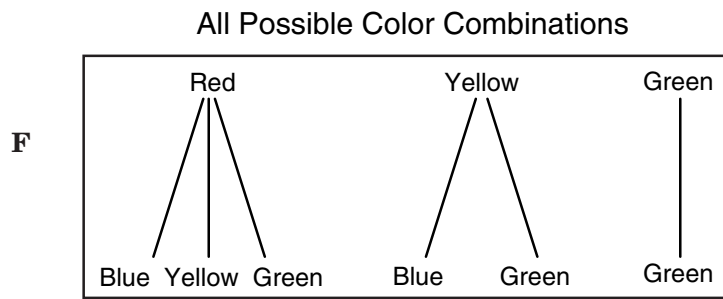

**23** Francesca used a square piece of poster board to show the main points of her history presentation. The length of each side of the poster board was 24 inches. Find the area of the poster board.

- A** 48 in.<sup>2</sup>
- B** 96 in.<sup>2</sup>
- C** 400 in.<sup>2</sup>
- D** 576 in.<sup>2</sup>

**24** There were 14 boats and 42 people registered for a boat race. Which ratio accurately compares the number of people to the number of boats?

- F** 2:6
- G** 3:1
- H** 7:21
- J** 14:42

**25** Scott has 5 green marbles, 8 red marbles, 2 purple marbles, and 6 blue marbles in a container. If he draws a marble at random from the container, what is the probability that he will NOT draw a blue marble?

- A**  $\frac{1}{4}$
- B**  $\frac{2}{7}$
- C**  $\frac{5}{7}$
- D**  $\frac{3}{4}$

26 Mr. Franks recorded these mathematics test scores of his sixth-grade students.

67, 69, 71, 73, 74, 75, 79, 81, 81, 82, 83, 87, 88, 88, 88, 88, 90, 91, 93, 95, 99, 100

What is the median of these test scores?

- F 83
- G 85
- H 87
- J 88

27 The drawing shows 2 circles that share a common center point.

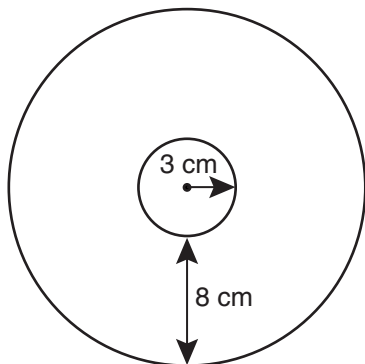

Which expression can be used to find the approximate circumference of the outer circle in centimeters?

- A  $\pi(3 + 8)$
- B  $\frac{1}{2}(3 + 8)$
- C  $2\pi(3 + 8)$
- D  $2(3 + 8)$

28 The table shows Andre's age and Maria's age over 4 consecutive years.

Ages

Andre's Age, $x$ (years)	Maria's Age, $y$ (years)
4	8
5	9
6	10
7	11

Which expression best represents Maria's age in terms of Andre's age?

- F  $x + 4$
- G  $2x$
- H  $y + 4$
- J  $2y$

- 29 David bought 2 shirts that were originally priced at \$26.50 each. Each shirt was on sale for \$3.98 off the original price when David bought them. Which equation can be used to find  $t$ , the total sale price of the 2 shirts?

- A  $t = 26.50 - 3.98$
- B  $t = 2(26.50) - 3.98$
- C  $t = 2(3.98) - 2(26.50)$
- D  $t = 2(26.50) - 2(3.98)$

- 30 The drawing below shows the shape of a plot of land.

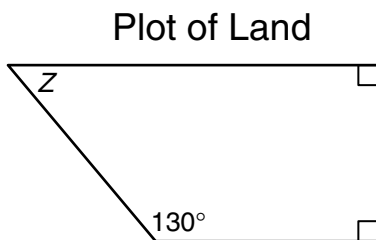

Find the measure of  $\angle Z$ .

- F  $40^\circ$
- G  $50^\circ$
- H  $90^\circ$
- J  $180^\circ$

- 31 Each number in the sequence below has the same relationship to the number immediately before it.

$$24, 12, 6, 3, 1\frac{1}{2}, \dots$$

How can the next number in the sequence be found?

- A By subtracting 12 from the previous number
- B By adding  $1\frac{1}{2}$  to the previous number
- C By multiplying the previous number by 2
- D By dividing the previous number by 2

- 32 Linda bought 2 blouses for a total of \$52 and 3 equally priced dresses. She spent a total of \$148, not including tax. Find the price of each dress.

- F \$26
- G \$32
- H \$52
- J \$55

- 33** The weight limit for an elevator is 2,000 pounds. Which statement is best supported by this information?
- A** The elevator can carry more than 20 adults.
  - B** The elevator can carry more than 20 crates that weigh 100 pounds each.
  - C** The elevator can carry up to 8 people who each weigh as much as 250 pounds.
  - D** The elevator can carry twice as many children as adults.

- 34** On Tuesday night Lucas spent 18 minutes on social studies homework, 29 minutes on language arts homework, and 59 minutes on mathematics homework. About how much time in all did Lucas spend on his homework?

- F** 1 hour 50 minutes
- G** 1 hour 10 minutes
- H** 1.5 hours
- J** 1.10 hours

- 35** If the ratio of boys to girls in the sixth-grade chorus is 2 to 3, which of these shows possible numbers of the boys and girls in the chorus?

- A** 20 boys, 35 girls
- B** 24 boys, 36 girls
- C** 35 boys, 20 girls
- D** 36 boys, 24 girls

- 36** The low temperature on Saturday was 10 degrees below zero Celsius. On Sunday the low temperature was 30 degrees above zero Celsius. What integer represents the low temperature on Saturday in degrees Celsius?

- F** 20
- G** 10
- H** -10
- J** -20

- 37** A certain regular polygon is made of congruent equilateral triangles. The table shows the relationship between the area of the triangle and the area of the polygon it is part of.

Triangles in Polygons

Area of Triangle (square units)	Area of Polygon (square units)
3	18
4	24
5	30
6	36
$n$	

Which expression can be used to find the area of a similar polygon made of triangles with an area of  $n$  square units each?

- A**  $1n$
- B**  $6n$
- C**  $n + 6$
- D**  $n + 36$

38 At a spring band concert, a prize was awarded to the person sitting in the chair numbered with the least common multiple of 12, 15, and 30. Find the number of the prizewinning chair.

- F 60
- G 45
- H 30
- J 15

39 Which point best represents the location of the ordered pair  $(1\frac{3}{4}, 2)$ ?

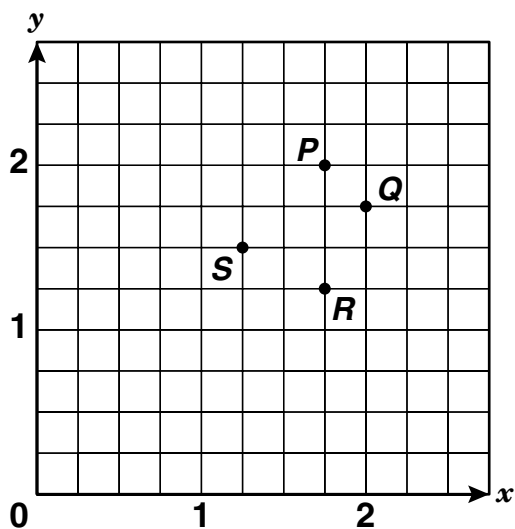

- A Point P
- B Point Q
- C Point R
- D Point S

40 Triangle  $XYZ$  is an isosceles triangle. If the measure of  $\angle Z$  is  $32^\circ$ , what is the measure of  $\angle Y$ ?

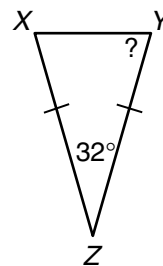

- F  $32^\circ$
- G  $74^\circ$
- H  $148^\circ$
- J  $164^\circ$

- 41 Antonio saved \$30 to go to a carnival. He needs a certain amount of money for bus fare and admission. Antonio wants to find the amount of money he will have left for rides and food.

Look at the problem-solving steps shown below. Arrange the steps in the correct order for Antonio to find the amount of money he will have left for rides and food.

Step P: Identify the cost of bus fare and then the cost of admission.

Step Q: Find the difference between \$30 and the sum of the costs of bus fare and admission.

Step R: Find the sum of the costs of bus fare and admission.

Which list shows the steps in the correct order?

- A P, Q, R
- B Q, P, R
- C P, R, Q
- D Q, R, P

- 
- 42 Harold made a drawing of his rectangular kitchen for art class. The length of the drawing was 8.6 inches, and the width of the drawing was 2.5 inches less than the length. Find the width of the drawing.

- F 6.1 in.
- G 8.6 in.
- H 11.1 in.
- J 21.5 in.

- 43 Valerie listed the coordinates of 5 of the vertices of the hexagon below.

(1, 2), (1, 4), (2, 1), (4, 1), (5, 5)

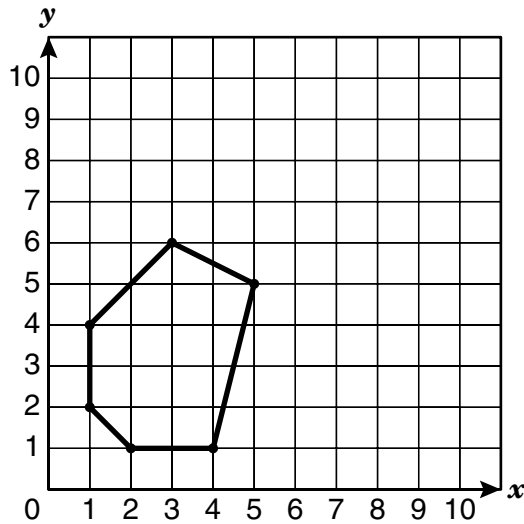

Which of these shows the coordinates of the vertex that Valerie did not list?

- A (1, 3)
- B (3, 1)
- C (3, 6)
- D (6, 3)

- 44 For a science project Ruth is keeping track of the calories her father eats at breakfast. The table shows the number of calories he ate at breakfast on Monday.

Breakfast Calories

Food	Number of Servings	Number of Calories per Serving
Oat Cereal	1	80
Skim Milk	1	40
Orange Juice	1	86
Banana	1	105
Flavored Coffee	1	55

Which is closest to the number of calories Ruth's father ate at breakfast on Monday?

- F 200 cal
- G 300 cal
- H 400 cal
- J 500 cal

- 45 Mr. Chávez distributed 78 sheets of drawing paper to the art students in his class. Each student received 3 sheets of drawing paper. Which equation can be used to find  $s$ , the number of students in the class?

- A  $s = 78 \div 3$
- B  $s = 75 - 3$
- C  $s = 78 \times 3$
- D  $s = 78 + 3$

- 46 Of the 100 people An Li surveyed about their favorite sport, 45 said football, 30 said wrestling, 20 said baseball, and 5 said basketball. Which circle graph best displays the data?

F Favorite Sports

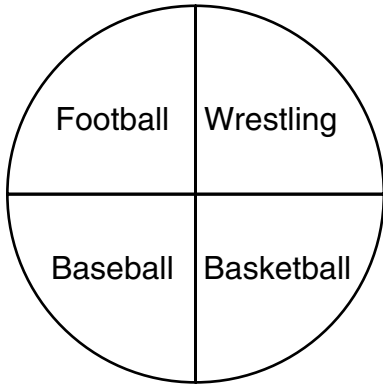

H Favorite Sports

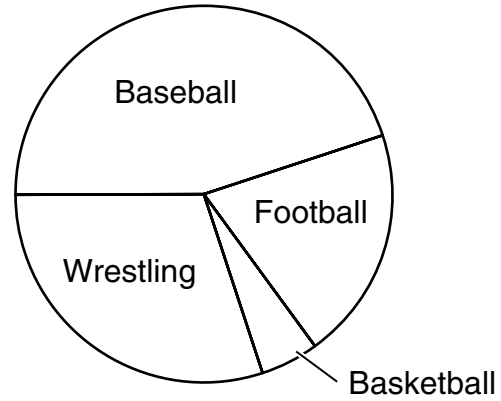

G Favorite Sports

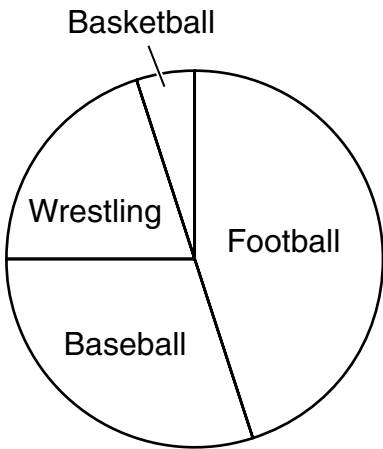

J Favorite Sports

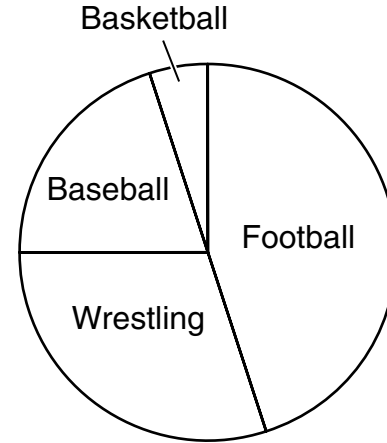

BE SURE YOU HAVE RECORDED ALL OF YOUR ANSWERS  
ON THE ANSWER DOCUMENT.

